

The logo for Indmar Marine Engines features the brand name in a bold, italicized red font. The background of the entire page is a close-up photograph of blue water with shimmering, wavy patterns.

Indmar

M A R I N E E N G I N E S

O p e r a t o r ' s M a n u a l

IMPORTANT SAFETY INFORMATION

Throughout this manual, specific precautions and symbols identify safety related information.

 The Safety Alert Symbol means ATTENTION!
BECOME ALERT! YOUR SAFETY IS INVOLVED!



Indicates the presence of a hazard which **WILL** cause **SEVERE** injury, death or substantial property damage.



Indicates the presence of a hazard which **CAN** cause **SEVERE** injury, death or substantial property damage.

CAUTION

Indicates the presence of a hazard which **WILL** or **CAN** cause **MINOR** or **MODERATE** personal injury or property damage.

NOTICE

Indicates installation, operation or maintenance information which is important but not hazard-related.

The precautions listed in this manual and on the engine or boat are not all-inclusive. If a procedure, method, tool or part is not specifically recommended, you must satisfy yourself that it is safe for you and others, and that the engine or boat will not be damaged or made unsafe as a result of your decision.

WELCOME

Dear Indmar Marine Engine Owner,

Congratulations on selecting the finest marine inboard power available for your boat; Team Indmar welcomes you to our family of owners! Indmar proudly stands behind our products and is the first inboard manufacturer to offer a 3-year limited warranty.

We want you to know that your engine was manufactured to surpass industry standards. Before leaving the factory, your engine was tested for operational performance. Operational performance data will be retained to track product performance in the future. It's our goal to continually improve our product and deliver all the benefits of the latest power technology.

If you have any questions concerning your engine, please feel welcome to contact Indmar Customer Service at (901) 353-9930 or E-Mail us at gearhead@Indmar.com. You can write us at Indmar Products Company, Inc., 5400 Old Millington Road, Millington, Tennessee 38053. On the Web, go to our site at www.indmar.com.

Again, thank you for choosing Indmar. We wish you safe, trouble-free boating.

Sincerely,

Team Indmar

Indmar Marine Engines

TABLE OF CONTENTS

Introduction	v
Chapter 1: First Time Operation and Break-In	1-1
Chapter 2: General Operations and Warnings	2-1
Chapter 3: Engine Starting Procedures	3-1
Chapter 4: Normal Operation	4-1
Chapter 5: Fuel	5-1
Chapter 6: Maintenance	6-1
Chapter 7: Storage and Winter Lay-up	7-1
Chapter 8: Troubleshooting	8-1
Appendix A – Maintenance Components and Fluids	A-1
Appendix B – Engine Specifications	B-1
Appendix C – Limited Warranty	C-1

INTRODUCTION

This manual will acquaint you with basic information needed to safely operate and maintain your Indmar engine. We suggest you and all other operators read the entire manual before using your boat.

We recommend you contact your Indmar dealer for all engine service. Certified Indmar Technicians are trained. They have current specifications, parts and the special equipment needed to service your Indmar engine and drive line. To find your nearest Indmar dealer, please call (901) 353-9930 or visit our website at www.indmar.com.

To ensure that the proper information is available, note the engine serial number. Your dealer should have written the engine serial number on your copy of the warranty registration card. Your copy of the warranty registration card should be in this Operator's Manual. The serial number is stamped on the engine block; see the diagram below for locations.

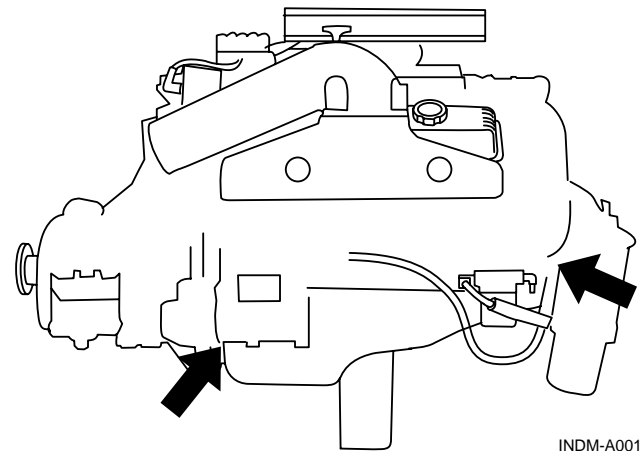

Figure 1.1 – Serial Number Locations

All Indmar engine ratings are determined at specific weather and elevation conditions. Changes in elevation, heat and humidity have a noticeable effect on the power of any engine. Some power can be regained by dropping to a lower pitch propeller but the basic problem of lower air density will affect the power output of the engine. If you are experiencing performance problems due to weather and/or elevation conditions, contact your Indmar dealer for recommendations.

Send your completed warranty form today!

The Federal Boat Safety Act of 1971 requires registrations of marine products sold in the United States be maintained by the manufacturer and dealers of those products. Your dealer should have completed your warranty registration card to comply with federal regulations. This registration enables us to contact you, if it should become necessary, to change or improve your product. The engine serial number is stamped into the block and should also be on your warranty card. Always retain a copy of the serial number for your personal records. If your dealer did not fill out the card and give you a copy, contact your dealer.

Warranty registration must be received within 10 days after date of purchase by the first owner. If your engine is not registered, all warranties may be void.

To obtain enjoyment from your boat, follow recommendations described in this manual. The knowledge you gain through careful review will help you experience lasting satisfaction.

Further information regarding the care, operation, required equipment or specifications for your boat can be obtained from your local US Coast Guard Auxiliary, US Power Squadron, state boating authorities, or the American Red Cross. Know the law and your responsibilities as a boat owner.

Any alteration, change, improper maintenance or abnormal use by you which renders the engine or any of its components unreasonably dangerous will void all warranties and Indmar will not be liable for the resulting damages or injuries.

Chapter 1

FIRST TIME OPERATION AND BREAK-IN

The following checks assume your dealer has performed the pre-delivery service and inspection. Complete the following pre-start check list before starting your engine for the first time. If you have questions about any of these procedures, see your Indmar dealer for assistance.

FIRST TIME OPERATION

1. Check the boat hull and/or garboard drain plug. Make sure they are installed and secure. Check the boat owner's manual for additional pre-operation checks.
2. Make sure all engine drain plugs are installed. Refer to Chapter 7, Storage and Winter Lay-up. There are several drain locations:

Block – Two drain plugs on each side; 5.7 Liter EFI engines have an Engine Knock Sensor (1, Figure 1-2) installed in one drain hole.

NOTICE

On the 8.1 Liter engine, removing the knock sensor does NOT drain the block. Remove the plugs from the brass fillings on both sides of the engine to drain water from the block.

Indmar Marine Engines

Exhaust – The drain hose must be connected.

Transmission – The transmission oil cooler has one drain plug. In addition, the Walters V-Drive (if equipped) has two drain plugs.

Fresh Water Cooling System – If equipped, the heat exchanger has four drain plugs; two for raw water and two for coolant. Refer to Chapter 7, *Storage and Winter Lay-up*.

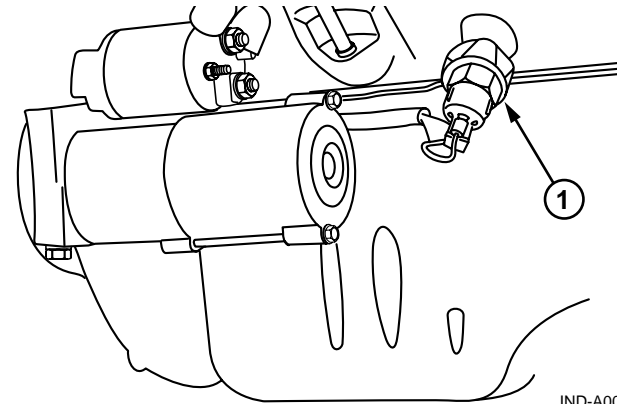

Figure 1.2 – Anti Knock Sensor

IND-A005

3. Make sure your battery is fully charged and the cables are clean and tight.
4. Check engine oil for correct level. Refer to Chapter 6, *Maintenance*.

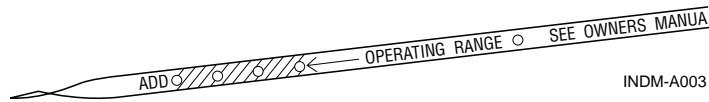

Figure 1.3 – Engine Dipstick Level

5. Check transmission oil level for correct level. Refer to Chapter 6, *Maintenance*.
6. If your engine is equipped with fresh water cooling, check the expansion tank for the correct level. Refer to Chapter 6, *Maintenance*.

CAUTION
Do not mix antifreeze types.

7. Inspect engine mounts to make sure they aligned and tight. Make sure that the propeller shaft coupler bolts are tight.

WARNING
Make sure the engine water intake is not blocked by the trailer bunk. Blocked or restricted water flow may damage the engine.

8. Back trailer into the water. Make sure the engine water intake is submerged.

DANGER

Before starting engine operate bilge blower at least 4 minutes and raise engine cover to ventilate fumes. Inspect engine and compartment for any fluid or fuel leaks. Failure to do so can possibly result in fire and/or explosion resulting in death or serious injury to you and your passengers.

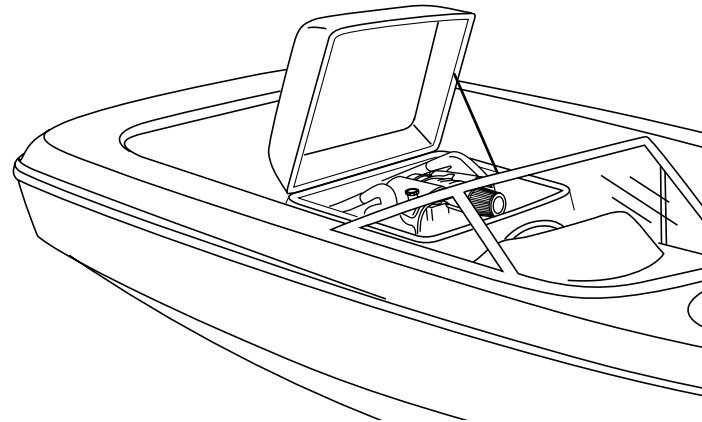

Figure 1.4 – Raised Engine Cover

NOTICE



Priming the EFI Fuel System is required before starting your EFI engine for the first time. This allows the electric fuel pump to fill the fuel injection lines with gasoline. Each time you advance the ignition switch to the "ON" position, the fuel pump cycles for 2 seconds.

NOTICE



Priming fuel system is not necessary with carbureted engines.

9. EFI Engines Only. Prime the fuel system by cycling the fuel pump eight to ten times before the engine is started for the first time. To prime:
 - Turn the ignition key ON for 5 seconds.
 - Turn the ignition key OFF for 5 seconds.
 - Repeat above eight to ten times

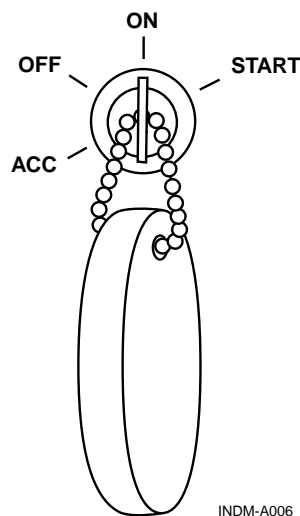

INDM-A006

Figure 1.5 – Engine "On" Switch

NOTICE



The above procedure is only necessary for the first time the engine is started or in the event the fuel tank is run dry. If your dealer prepares your boat for initial delivery, they will perform this procedure for you.

10. Start the engine (Refer to Chapter 2, General Operation and Warnings) and allow it to reach normal operating temperature; keep a close eye on the gauges. If any of the gauges indicate an engine problem, stop the engine immediately and bring the boat to your Indmar dealer for assistance.

CAUTION

Do not operate starter motor for more than 15 seconds without a 2 (two) minute cool-down period. Excessively long cranking times will permanently damage the starter motor and drain the battery.

Break-In

Taking care now to break-in your new Indmar engine is VERY important. When broken in properly, your engine will last longer, run better and require fewer repairs over its lifetime. Your new Indmar engine does not require an elaborate break-in procedure, just a little care and common sense for the first 7 hours.

Break-in Tips

- Always let engine warm up to normal operating temperature before accelerating. EFI engines, including the LS1, are programmed with a phased warm up to ensure that the engine is warm before full RPM is possible; refer to Table 1-1.

Table 1-1. EFI Phased Warm-Up

TEMPERATURE	TIME	RPM LIMIT
103°F (40°C) or less	-----	3000 RPM
104° to 139°F (41° to 59°C)	+ 10 seconds	4200 RPM
140° (60°C) and higher	+ 10 seconds	Full RPM

- Avoid fast accelerations and don't carry (or pull) a heavy load during this period.
- Check engine and transmission fluid levels frequently. During the first 50 to 100 hours, an engine can use more oil than usual. Maintain oil at proper levels at all times but do not overfill.
- Vary your boat speed during break-in. Do not run at the same speed very long.
- Observe gauge readings and check for loose mountings, fittings, nuts, bolts and clamps.
- Report abnormal operation, noises or vibrations to your dealer.

Break-in Steps

1. For the first hour, do not exceed 2000 RPM; vary RPM continuously.
2. For the second hour, do not exceed 3000 RPM;
3. For the next five hours, do not exceed 4000 RPM.

After the first ten hours of operation, take your boat to the dealer for its first engine and transmission oil and filter change and engine checkup. Your Indmar dealer is best equipped to check the engine immediately after break-in.

After the break-in procedure is over, your boat may be operated continuously at any speed. Be sure to check the wide open throttle operating range; refer to Chapter 4, Selecting A Propeller.

CAUTION

Do not exceed maximum RPM recommended for your engine. Exceeding the maximum RPM may result in damage to the engine.

Chapter 2

GENERAL OPERATION AND WARNINGS

Operating a boat is a safe and enjoyable experience.

Indmar marine engines use gasoline for fuel. The area under the engine and around the gasoline tank and supply lines is not open to outside air. Ventilation around these areas must be provided by your bilge blower system and air vents located around the boat. We recommend taking time out to carefully inspect your boat at least once a day for gasoline fumes, oil leaks, and areas where wiring may be worn or damaged.



Explosive gasoline and battery fumes may accumulate in your engine compartment. Failure to properly ventilate fumes with the bilge blower may result in explosive atmosphere resulting in death or serious injury to you and your passengers.



WARNING

Before starting engine operate bilge blower at least 4 minutes and raise engine cover to ventilate fumes. Inspect engine and compartment for any fluid or fuel leaks. Failure to do so can possibly result in fire and/or explosion resulting in death or serious injury to you and your passengers.

When refueling, make sure to open the motor box and run the blower during and after the re-fueling operation. Failure to do so may result in fire or explosion and may cause death or serious injury.



WARNING

Never remove or modify any components of the engine's fuel system. Tampering with fuel components may cause a hazardous condition that could result in severe personal injury or death. This work must be performed by your dealer's technicians.

Daily Pre-Start Checks

Refer to Chapter 6, *Maintenance* for checks and services.

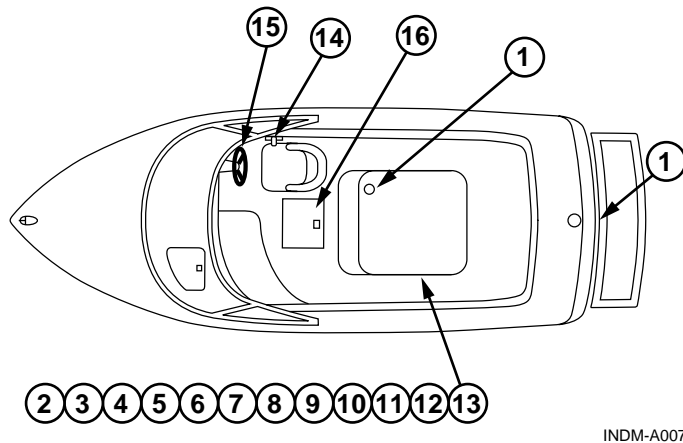

Figure 2.1 – Pre-Start Check Points

1. Verify boat hull and/or garboard drain plug are in place.
2. Carefully inspect engine compartment for signs of fluid leakage and proper ventilation. Unlike autos, marine engine compartments require positive ventilation and air re-circulation to ensure that flammable and explosive vapors are safely dispersed in an environmentally sound manner.
3. Verify engine drain plugs are in place.
4. Check engine oil level.

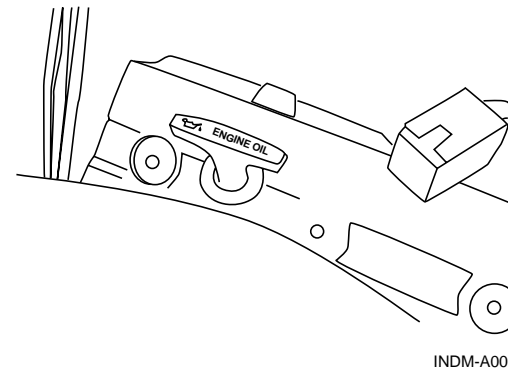

Figure 2.2 – Engine Oil Dipstick

5. Verify fuel lines are tight and there is no leakage present.
6. Inspect oil lines and oil filter. Ensure they are tight and no leakage is present.

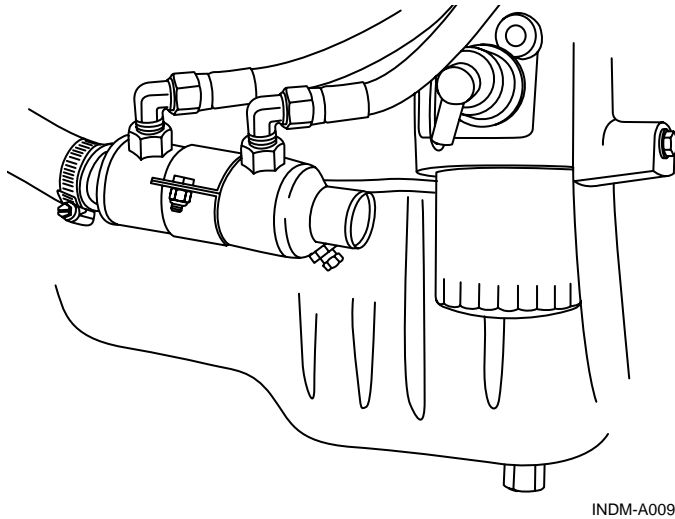

Figure 2.3 – Engine Oil Filter

7. Check transmission fluid level. Check V-Drive fluid level if equipped.
8. If your engine is equipped with a fresh water cooling system, check coolant level in the expansion tank.
9. Check alternator belt for wear and proper tension.
10. Verify that exhaust hoses are in good condition and clamped tight.
11. Ensure that the propeller shaft coupler bolts are tight.
12. Verify engine mounts are tight.

13. Check electrical connections and ensure connectors are tight. Check wiring for signs of wear and abrasion.
14. Verify throttle/shift control is functional and properly adjusted.
15. Verify steering controls are functional and properly adjusted.
16. Verify battery connections are clean and securely fastened.

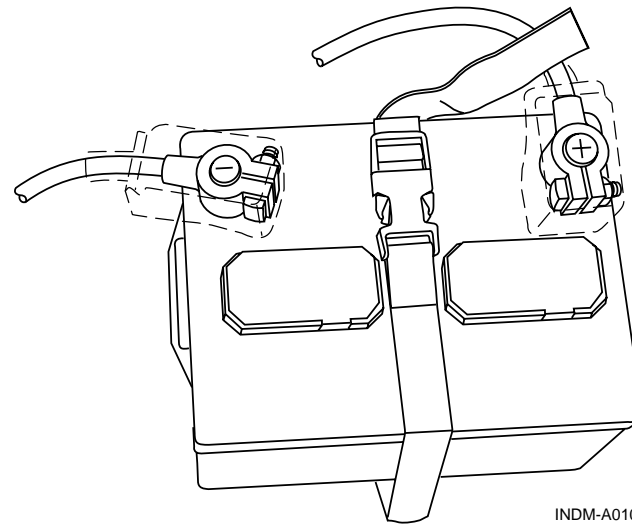

Figure 2.4 – Battery Connections

Chapter 3

ENGINE STARTING PROCEDURES



Explosive gasoline and battery fumes may accumulate in your engine compartment. Failure to properly ventilate fumes with the bilge blower may result in explosive atmosphere resulting in death or serious injury to you and your passengers.



Before starting engine operate bilge blower at least 4 minutes and raise engine cover to ventilate fumes. Inspect engine and compartment for any fluid or fuel leaks. Failure to do so can possibly result in fire and/or explosion resulting in death or serious injury to you and your passengers.

When refueling, make sure to open the motor box and run the blower during and after the re-fueling operation. Failure to do so may result in fire or explosion and may cause death or serious injury.



Never remove or modify any components of the engine's fuel system. Tampering with fuel components may cause a hazardous condition that could result in severe personal injury or death. This work must be performed by your dealer's technicians.

HOW TO START YOUR ENGINE

1. Run the blower for 4 minutes to remove explosive gasoline and battery fumes from the engine compartment.

2. Perform the Daily Pre-Start checks. Refer to Chapter 2, General Operation and Warnings.

3. Move the shift control lever to the NEUTRAL position. Pull out the neutral safety lever (if equipped). Without advancing the throttle lever, turn the starter key to START position.

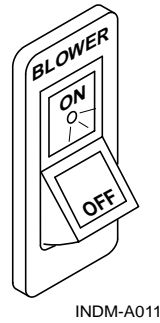

INDM-A011

Figure 3.1 – Blower Switch

NOTICE



Prime cold engine by moving throttle forward and back two or three times. Then return to idle position before starting. A hot engine does not require priming.

NOTICE



On carbureted engines it will be necessary to feather the throttle until the engine warms up.

NOTICE



Because of the electronic engine controls, there is no need to advance the throttle to set an automatic choke. The throttle should be in the neutral position with the neutral detent button on the shift control box pulled out.

4. After the engine starts, release the key. The engine will gradually slow from a fast idle to normal idle. If engine is cold, it will operate at a slightly higher idle speed until warm-up is complete.

Make sure that when you

do shift into gear that you are at idle speed (less than 1100 RPM). Let engine warm up to normal operating temperature before accelerating. EFI engines, including the LS1, are programmed with a phased warm up to ensure that the engine is warm before full RPM is possible; refer to Table 3-1.

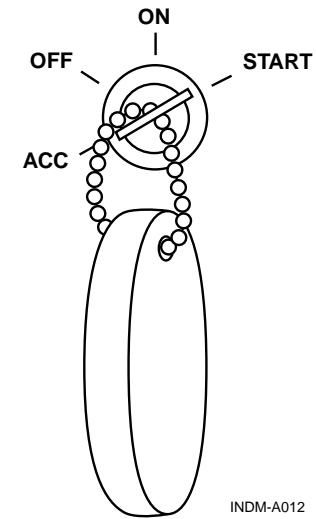

INDM-A012

Figure 3.2 – Start Position

Table 3-1. EFI Phased Warm-Up

TEMPERATURE	TIME	RPM LIMIT
103°F (40°C) or less	-----	3000 RPM
104° to 139°F (41° to 59°C)	+ 10 seconds	4200 RPM
140° (60°C) and higher	+ 10 seconds	Full RPM

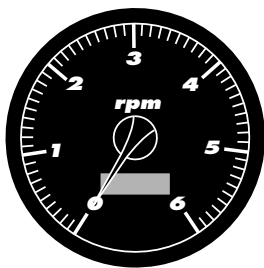

INDM-A013

Figure 3.3 – Tachometer

CAUTION

Once the engine has started, immediately check the oil pressure. Monitor the oil pressure and engine temperature closely for the first 10 minutes of operation.

IF ENGINE DOES NOT START

CAUTION

Do not operate starter motor for more than 15 seconds without a 2 (two) minute cool-down period. Excessively long cranking times will permanently damage the starter motor and drain the battery. Damage from overheating the starter motor is not covered by the warranty.

Hold key in START position for 3-5 seconds. If engine still does not start, advance throttle lever about 1/4 of its total travel. Turn key and hold it there for 12 more seconds until engine starts.

If your engine does not start after several attempts, it may have too much fuel and needs to be cleared.

HOW TO CLEAR THE ENGINE

1. Check throttle lever (1, Figure 3-4) to make sure it is pulled out (or Neutral lockout button, 2, activated) so that boat is still in NEUTRAL.
2. Wait for 30 seconds to allow starter motor to cool.

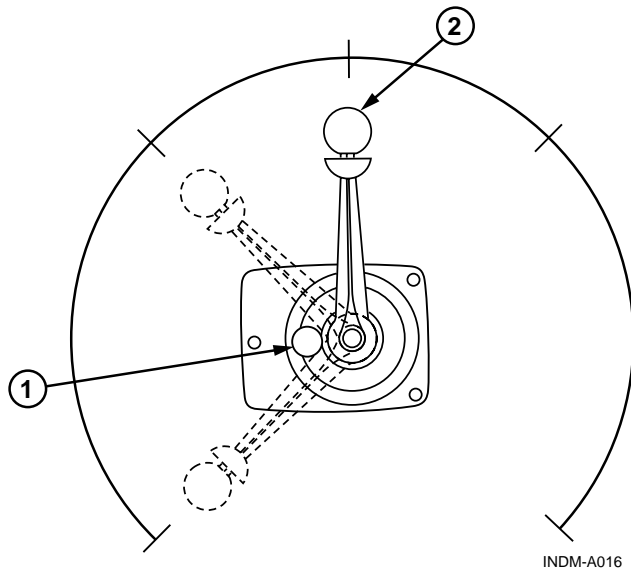

Figure 3.4 – Shift/Throttle Lever

3. Advance throttle lever to full throttle position and hold. Hold key in START position for no more than 10 seconds to clear extra gasoline from the engine. When engine starts, immediately return throttle handle to IDLE position.
4. If it does not start, wait two minutes and try the sequence again.

ENGINE RESTART

1. If your engine is already warm and will not re-start, turn key to ON position and wait for about 20 seconds (not necessary with carbureted engine).
2. Make sure that your throttle lever is in NEUTRAL.
3. Turn key OFF. Try to start engine again. If it does not start, advance throttle to about 1/4 while holding key in the START position. (Remember, you should only hold key in start position for 12 seconds at a time.) When engine starts, release the key and immediately return throttle to IDLE position.

NOTICE



Your engine is designed to work with the standard electronics installed in your boat. If you add electrical components or accessories, you could change fuel injection controls for your engine or could exceed the amperage capacity of the wiring and protection system. Before adding electrical equipment, consult your Indmar dealer.

Chapter 4

NORMAL OPERATION

DAILY ROUTINE

1. Open the engine cover and check the bilge for water; pump bilge dry. Excessive amounts of water can indicate leakage problems from shaft/rudder logs, thru-hull fittings, loose or damaged hoses or hull damage. Excess water in the bilge will damage engine components (starters, alternators, etc.).

CAUTION

Do not allow excessive amounts of water to remain in the bilge. Component damage due to water is not covered by the warranty.

2. Follow the starting procedures outlined in Chapter 3, *Engine Starting Procedures*.



WARNING

Don't forget to run your engine blower for at least 4 minutes before cranking engine. Failure to do so may result in fire and/or explosion resulting in death or serious personal injury.

3. Once the engine is started, allow it to reach operating temperatures of at least 120°-140° F (49°-60° C) before accelerating to speeds above 3000 RPM. EFI engines, including the LS1, are programmed with a phased warm up to ensure that the engine is warm before full RPM is possible; refer to Table 4-1.

Table 4-1. EFI Phased Warm-Up

TEMPERATURE	TIME	RPM LIMIT
103°F (40°C) or less	-----	3000 RPM
104° to 139°F (41° to 59°C)	+ 10 seconds	4200 RPM
140° (60°C) and higher	+ 10 seconds	Full RPM

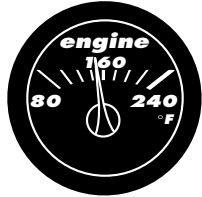

INDM-A015

Figure 4.1 – Temperature Gauge

4. Monitor your gauges and warning lights frequently to ensure that engine temperatures and pressures are within the proper ranges.

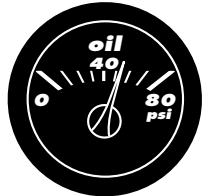

INDM-A014

Figure 4.2 – Oil Pressure Gauge

OPERATING THE CONTROLS

Be sure to refer to the boat owner's manual for additional information. Should there be any difference between the information presented in this manual and the boat owner's manual, the boat owner's manual should take precedence.

The shift / throttle control is important to daily operation. Have your dealer check it regularly for proper adjustment and lubrication.

NOTICE

 *Avoid using the throttle lever during the starting sequence. Your electronic engine controls should not need any throttle movement while starting.*

Your engine has a safety feature that allows the engine to crank only in the neutral position. If during the starting process your engine will not turn over, make sure that the shift / throttle control is in the NEUTRAL position and try again.

Most boats have an **engine safety switch** (1, Figure 4-3) that can be activated if the driver moves from the helm position. If you experience a “no start” condition, verify that this switch has not been disabled. If the tether cord is pulled from the switch, it disables the ignition system so the boat cannot start.

Use **caution while operating shift lever**. Shift only while the engine is at idle.

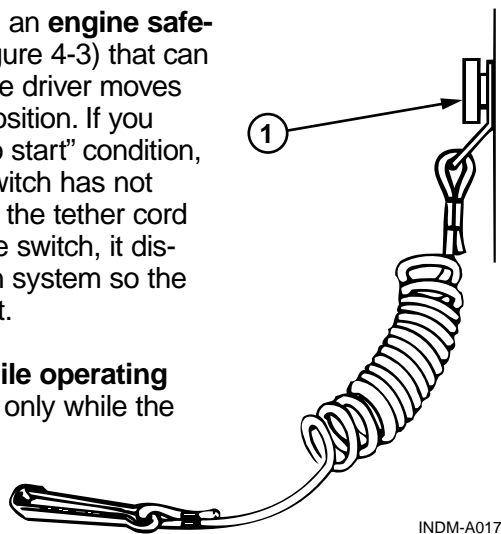

Figure 4.3 – Tether Cord and Safety Switch

CAUTION

Avoid using the throttle when in reverse. This can force water backwards into the exhaust system and into the engine cylinders with major damage.

CAUTION

HYDROSTATIC LOCK: If water collects in the engine cylinder for any reason, it can cause hydrostatic lock, not allowing the pistons in the engine to move properly. Hydrostatic lock can severely damage your engine which is not covered by your warranty.

UNUSUAL VIBRATION

If your engine is used in a direct coupled application (inboard) you need to know that damage to the drive line (propeller, shaft, strut and coupling) can cause vibration. You may feel vibration if damage is severe. Vibration in the drive line will cause excessive wear on transmission and engine components.

If you believe you hit something with the propeller, or if you notice excessive vibration, see your dealer. Damage to your engine, drive line, or transmission caused by vibration is not covered by your warranty.

FUEL SYSTEM

The Indmar fuel system uses high quality marine grade components. These components will tolerate small amounts of water without sustaining damage. Your engine will misfire and run poorly, however, if water is in the fuel. Use caution when re-fueling not to allow water to enter the fuel system. If you suspect your fuel is water contaminated, consult your dealer and avoid that fuel source in the future.



WARNING

Do not attempt to repair or replace any components of the fuel system. They are special marine parts and may require special service tools. You could damage the fuel system by not using specified tools. This could cause a fire or explosion and subsequent death or serious personal injury to you or your passengers.

See your dealer for assistance with fuel system repairs.

BATTERY

Your engine uses a special 12-volt marine battery. If a replacement is needed, use only a marine battery with minimum 650 cold cranking amps at 0° F (-18° C).

Before disconnecting the battery, make sure the battery switch (if equipped), ignition key and all accessories are in the OFF position.

Be sure to connect cables properly:

- Black cable to the negative or (-) post
- Red cable to the positive or (+) post

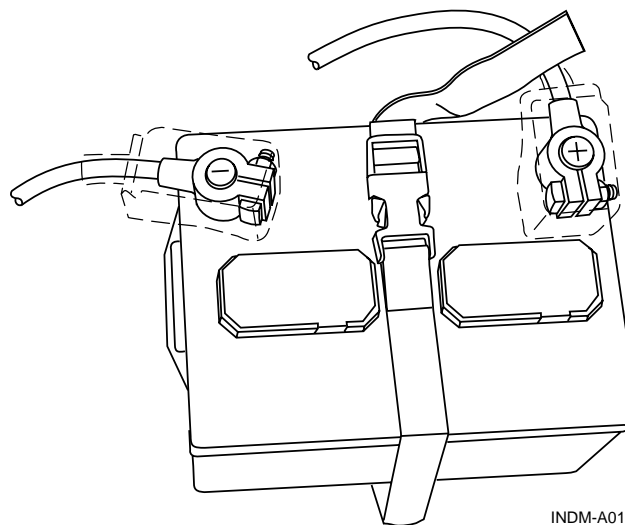

INDM-A010

Figure 4.4 – Marine Battery

CAUTION

Use caution when connecting the battery cables. Improperly connecting the battery cables or using the wrong battery type can damage electrical components. These damages are not covered by your warranty.

CHECK ENGINE LIGHT (EFI ENGINES ONLY)

Some boats are equipped with a Check Engine light which alerts you when the ECM (engine control module) detects a possible engine problem. If the light goes on, return to dealer for service. When a problem is detected, EFI engines may enter a Power Reduction mode. Power reduction limits the engine speed to a “safe maneuvering” speed of about 1600 RPM. This mode is intended to allow the driver to get out of harms way and to reach safe harbor for engine service.

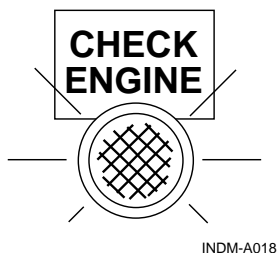

Figure 4.5 – Check Engine Light

The Check Engine light may activate if any of the following conditions are noted:

- Low Oil Pressure
- High Coolant Temperature
- High Transmission Oil Temperature

Any of these conditions will also put the engine into Power Reduction mode. If the Check Engine light should go on, or if the engine enters the Power Reduction mode, you should have your dealer check the engine as soon as possible.

CAUTION

Schedule engine service at once when this light is illuminated. Failure to have your engine serviced when a check engine light signal is given, may cause damage to your engine or your emissions system.

The ECM also provides for a tapered engine RPM reduction if engine coolant temperature approaches the high operating limit. If the coolant temperature exceeds 176° F (80° C), the engine RPM is gradually reduced until a safe temperature is reached. If the engine RPM should decrease due to high coolant temperature, stop the engine and inspect the raw water intake, sea cock and sea strainer (if equipped) and hoses for blockage or problems.

CHECK TRANSMISSION LIGHT

If the engine is equipped with the Walters V-Drive transmission, there is also a Check Transmission light. If low oil pressure is sensed in the V-Drive, the light will go on indicating the problem. Under normal operation, the light will stay lit at idle and slow speed operation until enough pressure is produced (1200 RPM \pm 400 RPM). Extended cruising or trolling at low RPM is not harmful, even if the light is lit, provided that the V-Drive oil level is sufficient. If the oil level is normal and the light stays lit above 2000 RPM, take the boat to your Indmar dealer for service.

ENGINE COOLING

Raw water cooled engines have two water pumps. One circulates water throughout the engine. The other pump uses water from the sea, lake or river to feed raw water to the engine. This raw water pump is designed to use the water it pumps to lubricate its impeller. Do not run the engine unless the boat is in water. If you run the engine with the boat out of the water, the water pump may be damaged, causing your engine to overheat or start a fire.

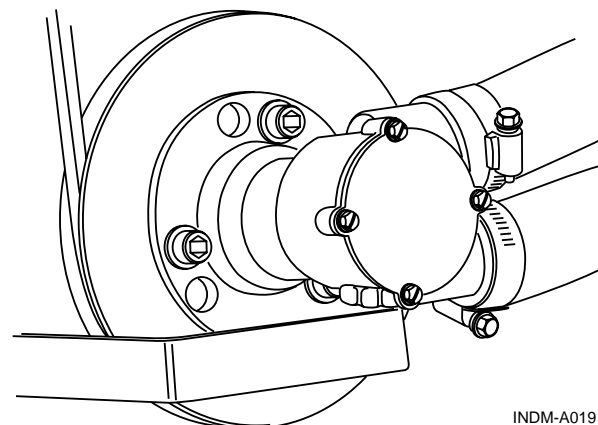

Figure 4.6 – Raw Water Pump



WARNING

Running engine without adequate cooling can cause engine to overheat and may result in fire, explosion, death and/or personal serious injury.

CAUTION

Running your engine with your boat out of water will damage or ruin your engine. Damage to your engine caused by overheating is not covered by your warranty.

CAUTION

Running the engine during the RPM reduction phase may cause severe damage to your engine.

- Monitor the temperature and oil gauges continuously.
- If the temperature rises past 200° F (93° C), or your oil pressure drops below 4 psi (41 kPa), STOP THE ENGINE IMMEDIATELY.

Damage due to running the engine with excessive temperature or low oil pressure is not covered by your warranty.

EXHAUST HOSES

Exhaust hoses on most boats carry exhaust gases from the engine outside of the boat. These hoses carry water that has been used to cool the engine. This water keeps the hoses cool and prevents them from melting.

Indmar Marine Engines



Carbon monoxide gas (CO) is colorless, odorless and extremely dangerous. All engines and fuel burning appliances produce CO as exhaust. Direct and prolonged exposure to CO will cause **BRAIN DAMAGE** or **DEATH**. Signs of exposure to CO include nausea, dizziness and drowsiness. Ensure adequate ventilation to prevent accumulation of CO in the boat.

Monitor the engine temperature gauge frequently. If your engine overheats, carefully inspect the exhaust hoses for damage. Damaged hoses can allow carbon monoxide gas to enter your boat.

SELECTING A PROPELLER

For best engine performance and longevity, the wide-open-throttle (WOT) engine operation must be near the top of, but within, the specified WOT operating range. To adjust the WOT operating range, you must select a propeller (propping) with the proper diameter and pitch. The propeller which was supplied with your boat was chosen by the boat builder for best all-around performance under average conditions.

Load, weather, altitude and boat condition all affect WOT engine operation. If you use your boat for several different applications such as wakeboarding, barefooting and cruising, it may be necessary to have 2 or more propellers which will allow the engine to operate in the WOT range for each application.

Propping the boat should be done after engine break-in and the initial 10 hour dealer check. The boat should be loaded the way it would normally be for each application. For instance, if you are propping for wakeboarding, fill the ballast tanks if equipped and add all the people and gear you would normally expect to carry in the boat. Take the boat out and after warm-up, run it at wide-open-throttle and note the maximum RPM. EFI Engines are equipped with RPM limiters to prevent over-revving. Take note if the RPM limiter is activated.

If the WOT RPM is higher than the maximum RPM in your engine's WOT operating range, the boat is under-propped. Install a higher pitched propeller to reduce WOT RPMs. An engine that is over-revving may quickly experience catastrophic damage.

If the WOT RPM is lower than the minimum RPM in your engine's WOT operating range, the boat is over-propped. Install a lower pitched propeller to increase WOT RPMs.

An engine that is under-revving is lugging. Lugging places tremendous loads on the pistons, crankshaft and bearings and can cause detonation, piston seizure and other engine damage.

Elevation and weather also have a very noticeable effect on the wide-open-throttle power of an engine. Since air (containing oxygen) gets thinner as elevation increases, the engine begins to starve for air. Humidity, barometric pressure and temperature have a noticeable effect on the density of air since heat and humidity thin the air. This phenomenon can become particularly apparent when an engine is propped out on a cool dry day in spring and later, on a hot, humid day in summer, does not have the same performance. Although some performance can be regained by dropping to a lower pitch propeller, the basic condition still exists. The propeller is too large in diameter for the reduced power output. An experienced marine dealer can determine how much diameter to remove from a lower-pitch propeller for specific high-elevation locations.

Indmar suggests that if you do require a different propeller, consult the dealer you bought the boat from. The dealer is best equipped to help with the selection of the correct propeller for your application(s).

Chapter 5

FUEL

WHAT TYPE OF GASOLINE TO USE

All carbureted and standard EFI engines run on unleaded fuel of 89 Octane (R+M)/2 or higher. The LS1 requires 93 octane or higher. Fuels must meet the specification ASTM D4814 in the US and CGSB 3.5-92 in Canada. These fuels need no additives.

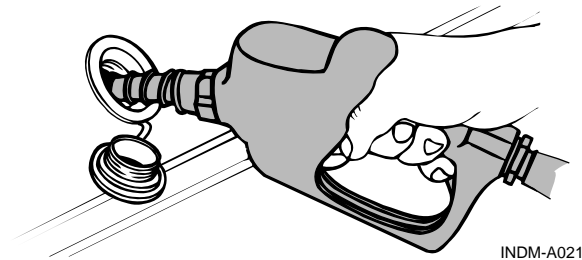

Figure 5.1 – Filling Fuel Tank



WARNING

Gasoline vapors are highly flammable and explosive.

- Never smoke while refueling. Keep sparks and flames away from fuel.
 - Only refuel in well ventilated area.
 - Never overfill fuel tank.
 - Stop engine before fueling.
 - Swallowing or inhaling gasoline or fumes is dangerous. Seek medical attention.
 - Gasoline spills on your skin should be washed immediately with soap and water. If gasoline spills on clothing, change clothing immediately.
- * Avoid spilling gasoline. Clean spills with dry cloth and dispose properly.

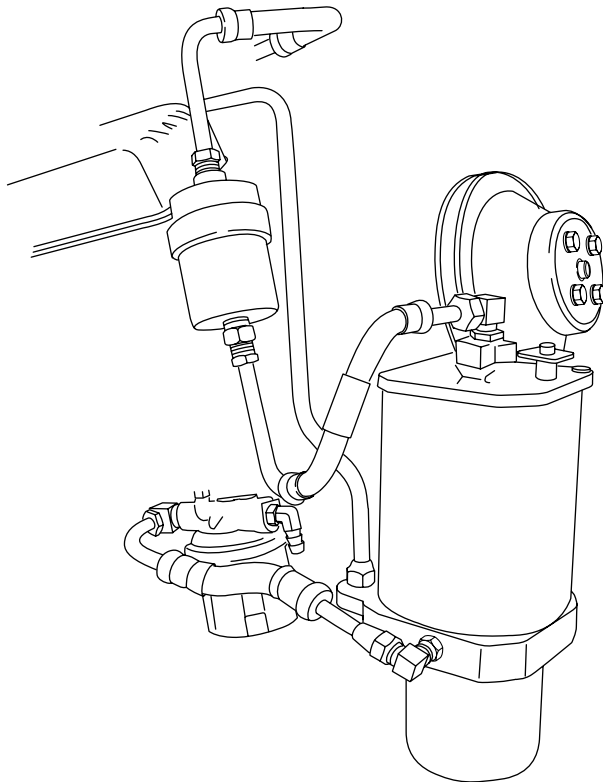

INDM-A022

Figure 5.2 – Inspecting Fuel Lines

CAUTION

Frequently inspect fuel lines and connections for leaks or deterioration.

Indmar recommends the regular use of Sta-Bil fuel stabilizer for boat users that consume less than a tank of fuel every two weeks. Today's fuels are more susceptible to degradation and the use of a quality stabilizer will help ensure fewer problems for the occasional boater.

If your boat has not been used for more than 30 days with fuel in the tank (even stabilized fuel), the engine may run poorly until the "old" fuel is used up. Indmar will not pay for repairs to carburetors or fuel injection components that are inoperable or damaged from old and/or poor quality fuel.

USING OXYGENATED FUELS OR FUELS WITH ALCOHOL

MBTE (methyl butyl tertiary ether) is an oxygenate and octane enhancer. This compound may be blended with fuel. Fuel that is no more than 15% MBTE is acceptable for use in your Indmar engine.

Ethyl alcohol, ethanol or grain alcohol is acceptable as long as it is a blend and the blended fuel contains no more than 10% ethanol.

CAUTION

Fuels that are blended to contain methanol or wood alcohol should not be used in Indmar engines. These fuels can corrode metal parts in your fuel system and engine. Fuels that contain methanol will damage your engine. Damage caused by the use of fuels that contain methanol is not covered by your warranty.

FUELS IN OTHER COUNTRIES

If you operate your Indmar engine outside the USA or Canada, unleaded fuels may be difficult to obtain. Leaded fuels are not recommended as engine components will last longer using unleaded fuel.

Chapter 6

MAINTENANCE

GENERAL SERVICE NOTES

Your Indmar dealer is your best source for engine repair and maintenance. Indmar certified technicians attend ongoing service training programs and have the proper diagnostic tools plus the latest specifications for your engine.



Electrical, ignition and fuel system components on Indmar engines comply with U.S. Coast Guard rules and regulations to minimize risks of fire or explosion. Use of replacement electrical, ignition or fuel system components, which do not comply to these rules and regulations, could result in a fire or explosion hazard and should not be used.

Your safety depends on your use of marine parts. When servicing the electrical, ignition and fuel systems, it is extremely important that all components are properly installed and tightened. If not, any electrical or ignition component could permit sparks to ignite fuel vapors from fuel system leaks, if they existed.

Since marine engines are expected to operate at near full-throttle for most of their life, and to operate in fresh and salt water environments, many special parts and fasteners are used which are quite different from standard automotive parts. Many parts are made from special corrosion resistant materials while other moving parts are heavy-duty for continuous, high RPM duty. If you perform minor service procedures, make sure to use genuine Indmar parts for marine use.



WARNING

- You can be injured if you try to work on your marine engine without knowing enough about your engine.
- Be sure you have the knowledge, experience and the correct replacement parts **BEFORE** you attempt any repairs.
- Be sure all fasteners you use are approved and rated for marine use. Use of improper parts can cause component or engine failure which may result in death or serious personal injury.

CAUTION

Never operate engine without adequate water supply to the raw water pump. Failure to properly cool engine will cause severe engine damage and void your warranty.

Scheduled Maintenance Chart

ITEM	SERVICE	FIRST 10 HOURS	EVERY 50 HOURS	EVERY 100 HOURS	EVERY 300 HOURS or ANNUALLY	EVERY 2 YEARS
Engine Oil & Filter	<i>Change</i>	X	X		X	
ZF Transmission Fluid	<i>Change</i>	X			X	
Walters V-Drive Oil	<i>Change</i>	X			X	
Engine Coolant	<i>Change</i>					X
Fuel Filter	<i>Replace</i>	X		X	X	
Spark Plugs*	<i>Replace</i>				X	
Engine Timing*	<i>Check</i>	X			X	
Engine*	<i>Tune Up</i>				X	
Flame Arrestor	<i>Clean/Change</i>			X		
Belts	<i>Inspect</i>	X		X	X	
Shaft Alignment	<i>Check</i>	X			X	
Spark Plug Wires*	<i>Inspect</i>				X	
Raw Water Pump Impeller	<i>Inspect</i>			X	X	
Breather Hose*	<i>Clean</i>				X	
PCV Valve*	<i>Replace</i>				X	
Starter Bendix*	<i>Grease</i>		X		X	

* Services best accomplished by your Indmar dealer.

ENGINE OIL

Checking Oil

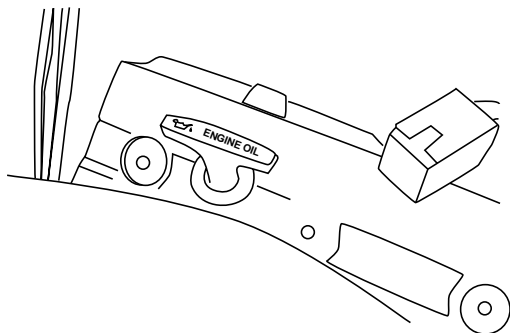

INDM-A023

Figure 6.1 – Engine Oil Dipstick Location

Check the oil level with the dipstick every time you get fuel. To get an accurate reading, your engine should be warm and the boat should be level. For best results wait about 2 minutes after you turn off the engine to allow the oil to drain into the oil pan, giving you a more accurate reading.

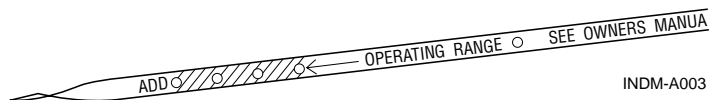

INDM-A003

Figure 6.2 – Dipstick

1. Pull dipstick from engine.
2. Wipe oil off stick with clean towel/cloth.
3. Insert dipstick completely into the dipstick tube.
4. Remove dipstick and read oil level.
5. After reading is complete, return dipstick to tube.
6. Add oil if necessary.

Adding Oil

If oil level on the dipstick reads below the ADD mark, add only enough oil to return level to FULL mark.

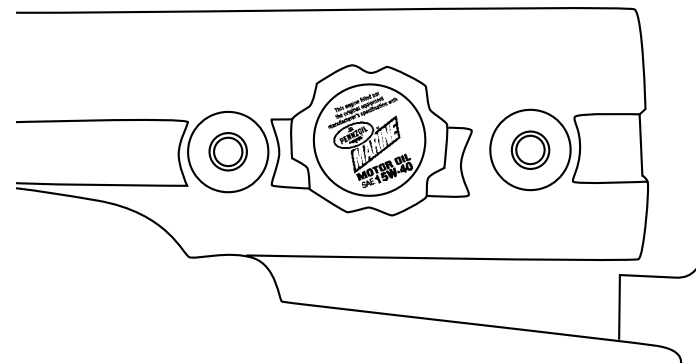

INDM-A025

Figure 6.3 – Engine Oil Fill

CAUTION

Do not overfill. If your oil level is above the full mark on the dipstick, the engine may be damaged.

Indmar uses and recommends Pennzoil Marine 15W-40 Marine Oil API Service SJ/CG4 or equivalent. If engine is to be used on conditions below 20° F (-7° C), use Pennzoil Marine SAE 10W-30 API Service SJ/CD or equivalent.

CAUTION

The use of engine oil other than 15W-40 with an API SJ/CG4 designation can cause engine damage. Damage to your engine caused by the use of improper oils is not covered by your warranty.

Synthetic Oil

Synthetic oil that meets our requirements of 15W40 and API SJ/CG4 is acceptable to use after 100 hours of operation with the recommended oil. The use of synthetic oil does not change the requirement of 50 hour oil change intervals.

Indmar Marine Engines

Changing Oil

Change your engine oil after the first 10 hours of operation. Then change oil every 50 hours or annually, whichever comes first. To maximize engine life, change the oil filter at every oil change.

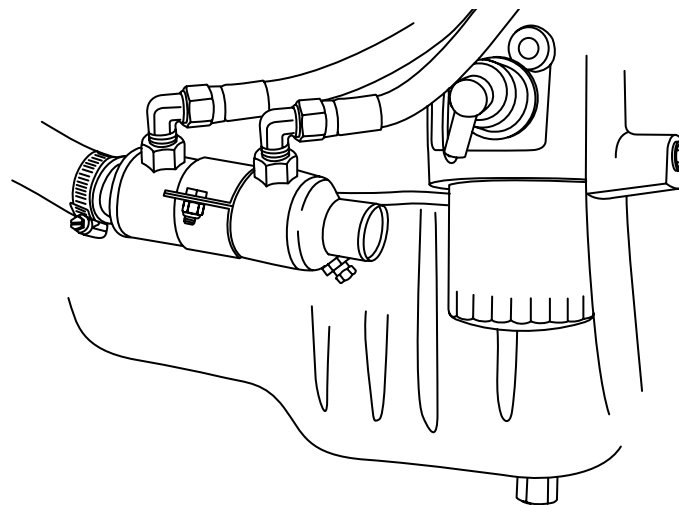

Figure 6.4 – Oil Filter

Indmar recommends all engine maintenance procedures be performed by your dealer, including oil changes. If you must perform the oil change yourself, operate the engine to full operating temperature.

CAUTION

Engine oil is hot. Be careful not to burn yourself.

1. With the boat level on trailer, remove the hull or garboard drain plug and insert QuickDrain through the hull opening (outside of hull).
2. Remove QuickDrain hose cap and let oil flow into used oil container.
3. When all oil has drained, replace cap and return QuickDrain to storage position. Replace the hull or garboard drain plug.
4. Position a suitable container under the oil filter. Unscrew and remove the oil filter; ensure that filter seal is removed with oil filter. Wipe up any spilled oil in the bilge and dispose of properly.
5. Fill a new Pennzoil Marine oil filter about 1/2 full with clean engine oil. Lightly lubricate the oil filter gasket and "spin on" the filter until the gasket makes contact. Hand tighten filter 1/4 to 1/2 turn after contact.
6. Add the new oil through the cap located on the engine valve cover. Fill only to the FULL mark of dipstick.
7. After initial start up, always carefully inspect oil drain plug and oil filter gasket area for leaks.
8. Stop the engine and re-check oil level. Add if necessary.

Oil Additives

Do not use oil additives. Indmar engines do not need oil additives. Use of recommended oil, along with regular oil and oil filter changes, will protect your engine adequately.

Disposing

Used engine oil contains dangerous chemicals and is considered a hazardous waste. Do not allow used oil to remain on your skin for any length of time. Make certain to drain all free flowing oil from the filter prior to disposal. Recycle used oil by taking it to a collection center. If you have a problem disposing of used oil, ask your Indmar dealer or service station for the name of a local oil recycling center for proper disposal.



WARNING

- **Prolonged and repeated contact with used engine oil may cause skin cancer.**
- **Avoid direct skin contact with used oil. If skin contact is made, wash thoroughly with soap or hand cleaner as soon as possible.**
- **Keep used engine oil out of reach of children.**
- **Used engine oil is a hazardous material. Dispose of properly.**

ENGINE FLAME ARRESTOR

Your engine is equipped with a U.S. Coast Guard approved flame arrestor. Its purpose is to contain any backfire that may occur during the operation of your engine. Because an inboard engine is completely enclosed, an uncontained backfire can be extremely dangerous.

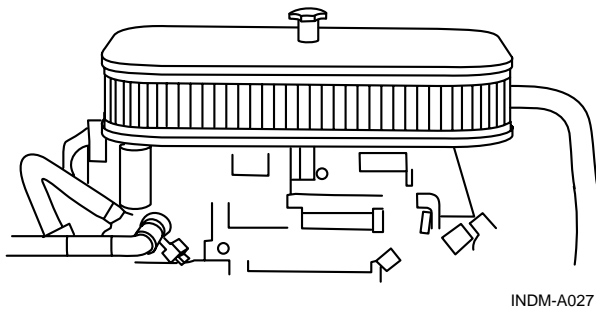

Figure 6.5 – Flame Arrestor

Periodically inspect flame arrestor to prevent clogging by dirt or corrosion. There are two types of flame arrestors used in Indmar engines, metal and paper.

Metal Type

The metal flame arrestor is cleaned using a mild part washing solvent. Using solvent, clean the flame arrestor

thoroughly and blow dry. The metal flame arrestor must dry completely before it is returned to the engine.

Paper Type

This type of flame arrestor should be blown clean from the inside monthly and replaced annually. Use only genuine Indmar replacement parts to ensure proper fit and protection against fire and explosion.

When cleaning or replacing the flame arrestor, clean the breather hose and replace the PCV valve at the same time.



WARNING

Do not remove the flame arrestor at any time when the engine is being started or run as it may result in fire, explosion and death or serious personal injury.

ENGINE COOLING



WARNING

Running engine without adequate cooling can cause engine to overheat and may result in fire, explosion, death and/or personal serious injury.



WARNING

Closed cooled engines are shipped from the Indmar factory filled with a 50/50 mix of Sierra brand antifreeze and water. This mixture provides freeze protection down to -26°F (-32°C). If the temperature in your area is expected to go below this level of protection, see your Indmar dealer to have the antifreeze mixture adjusted for your needs.

CAUTION

Running your engine with your boat out of water will damage or ruin your engine. Damage to your engine caused by overheating is not covered by your warranty.

Most engines are cooled by the raw water outside of the boat (Open Cooling System). For this reason, do not start the engine when the boat is out of the water without an engine flushing device available from your Indmar dealer.

With Open Cooling Systems, if your engine is used in salt, brackish, dirty or polluted water, the cooling system must be flushed with clean water immediately to prevent corrosion and blockage in the cooling system.

6-8

Open Cooling Systems usually consist of a raw water intake on the bottom of the boat, a strainer to filter weeds and debris, a raw water pump, a belt driven marine water pump, a thermostat to regulate engine temperature, and various connecting hoses. The raw water pump pulls outside water through the strainer, circulates the water through the engine and then discharges it overboard through a hose or with the engine exhaust.

Fresh Water (Closed) Cooling Systems

Some engines have a closed fresh water cooling system. In the fresh water system the cooling water contains anti-freeze and re-circulates throughout the engine. If your engine is equipped with a heat exchanger tank, it has a fresh water cooling system. Raw water is pulled through the strainer and flows through chambers in the heat exchanger and then discharged overboard with the engine exhaust.

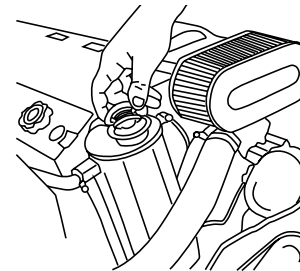

Figure 6.6 – Fresh Water Cooling System

Indmar Marine Engines

Check coolant level every time you check your oil. The level in the expansion tank should be maintained at 2/3 full when the engine is at operating temperature.



WARNING

To avoid possible skin burns, the engine must be turned “OFF” and cool enough so no heat is registered on the temperature gauge. Only after the engine is completely cooled is it safe for you to remove the coolant reservoir cap to check the level. Failure to follow procedure may result in death or serious personal injury.

CAUTION

- **Failure to maintain the coolant at the proper level can cause engine damage. Your warranty will not cover engine damage due to overheating or any other cause associated with improper coolant levels.**
- **Use only propylene glycol coolant. Use of any other coolant or mixing coolant types can cause engine damage. Damage to your engine from use of any other type of coolant is not covered by warranty.**

- **The coolant system should be flushed and coolant replaced every two years. This should be performed by a qualified Indmar service technician.**

When adding coolant, add only Sierra brand propylene glycol in an appropriate mixture with **distilled** water in accordance with the directions on the container. **Do not overfill the tank. Do not mix anti-freeze types.**

If tank is completely empty, see your Indmar dealer for assistance immediately to purge system. Purging the system is a difficult procedure that is not recommended for the boat owner.

FUEL SYSTEM

The fuel system consists of a fuel filter, water separator, fuel pump, and an unused fuel recovery system. Fuel in the system is under pressure and must be relieved before servicing. Because of the inherent danger of fuel leakage into the bilge, do not attempt servicing or maintaining components of the fuel system.

Your Indmar dealer has factory trained technicians and U.S. Coast Guard approved marine grade parts required for fuel systems.

TRANSMISSION

Indmar engines are equipped with one of three types of marine transmissions:

- Midships Mount: ZF Hurth Marine In-Line
- Stern Mount: ZF Hurth Marine V-Drive
- Stern Mount: Walters V-Drive and ZF Hurth In-Line

A separate owner's manual covering basic maintenance is provided with each transmission. The transmission fluid must be changed and the filter cleaned after the first 10 hours of operation and once each year thereafter. Refer to the transmission owner's manual for information.

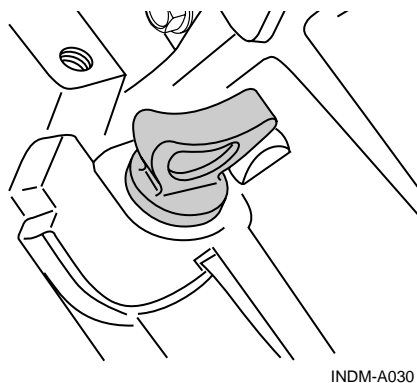

Figure 6.7 – ZF Hurth Transmission Dipstick Location
The transmission is water cooled by a heat exchanger

connected to the engine cooling system. The transmission fluid level should be checked each time the engine oil is checked. Fluid level is to be maintained at a level between the “Full” and “Add” marks on the transmission dipstick.

Overfilling the transmission with fluid will cause the seals to leak, and eventually lead to overheating, while if there is too little fluid, overheating will result.

If the engine uses the Walters V-Drive, it is equipped with a ZF Hurth in-line transmission for shifting. Be aware that the Walters V-Drive uses motor oil for lubrication, while the ZF Hurth transmission uses

Automatic Transmission Fluid. The Walters V-Drive also has a low oil pressure sensor and a dashboard mounted light. If low oil pressure is sensed, this lamp will light indicating the problem. Shut down the engine and check the transmission fluid level. Refer to Chapter 6, *Check Transmission Light* for more information.

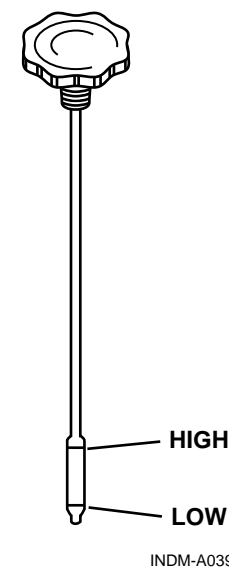

Figure 6.8 – Walters V-Drive Dipstick

If transmission service is required, note the Serial Number of the transmission stamped onto the ID plate on the top of the transmission housing. It is good practice to note the serial number noted and keep it with other owner related information.

Checking/Adding Transmission Fluid

Check fluid only with engine OFF and boat floating level, or level on trailer. The transmission dipstick is located on the top of the transmission. Dipsticks may be marked "ADD" and "FULL" or "H" and "L" (high and low); maintain fluid level between the two marks.

CAUTION

Check level immediately after turning engine off. Transmission fluid may be hot. Be careful not to burn yourself.

1. Remove the dipstick and wipe with a clean towel.
2. Insert the dipstick completely (do not screw in threaded dipstick to check fluid). Remove the dipstick and read fluid level.

3. Return dipstick after level check. Make sure it is secured in place.
4. If level is below "ADD" mark, add the proper fluid until it reaches the full mark. Add fluid through same tube as you removed the transmission dipstick.

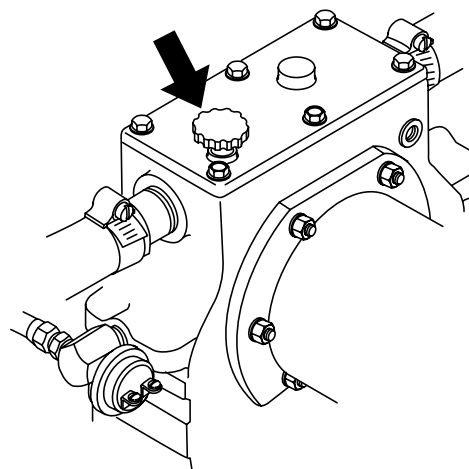

INDM-A031

Figure 6.9 – Walters V-Drive Dipstick Location

TRANSMISSION	MODEL	RATIO	CAPACITY	FLUID TYPE
ZF Hurth In-Line	450D	1:1	1.7 qt (1.6L)	Pennzoil Dexron II, III or MERCON
ZF Hurth In-Line	450A	1.5:1	2.12 qt (2L)	Pennzoil Dexron II, III or MERCON
ZF Hurth In-Line	630A	1.5:1	4.2 qt (4L)	Pennzoil Dexron II, III or MERCON
ZF Hurth V-Drive	630V	--	4.2 qt (4L)	Pennzoil Dexron II, III or MERCON
Walters V-Drive	RV-26D-71V	--	0.5 qt (0.5L)	Pennzoil SAE 30 Motor Oil

CAUTION

Do not overfill the transmission. Overfilling can damage the transmission. Damage to your transmission due to too much or too little fluid is not covered by your warranty.

ELECTRICAL SYSTEM

All Indmar engines are equipped with a 50 A circuit breaker (1, Figure 6-10) to protect the engine electrical system and components from overload. If the engine will not crank with the battery switch in the ON position, locate the red breaker reset button (labeled "50") at the back of the engine. Firmly push the red button until the breaker resets (an audible click will be heard). Start the engine.

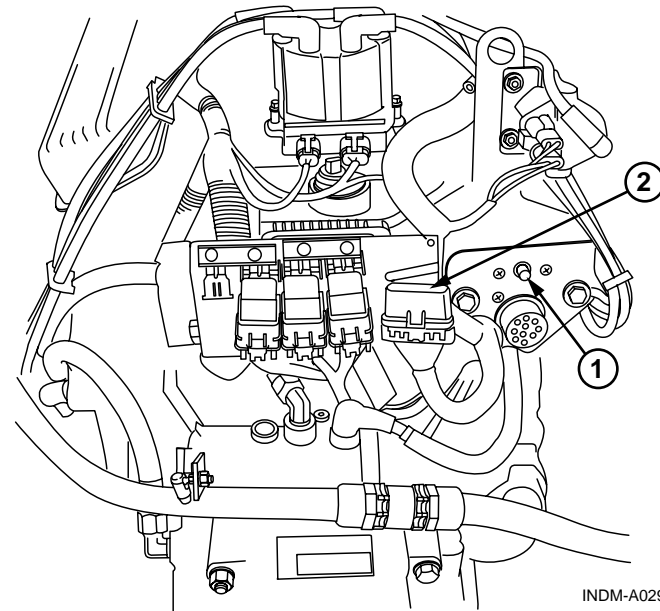

Figure 6.10 – Breaker Reset Button

If the breaker trips again, there is a problem with the electrical system. Take your boat immediately to your Indmar dealer for repair.

NOTICE



In addition to the 50 A Circuit Breaker, EFI Engines are equipped with additional component overload protection:

- Fuel Pump - 15 A ATO Fuse
- Injectors - 15 A ATO Fuse
- ECM - 15 A ATO Fuse

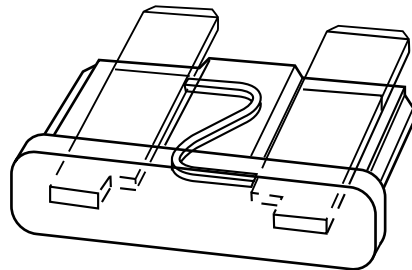

INDM-A032

Figure 6.11 – ATO Fuse

EFI fuses are located on the holder (2, Figure 6-10) attached with the ECM. To remove or inspect a fuse, remove molded plastic cap from fuse holder/base. Inspect fuse and replace if it is defective, (Figure 6-11).

Indmar Marine Engines

WIRING

If during maintenance or inspection, it becomes necessary to move or reposition any of the engine's wiring or wire harnesses, verify that wiring is returned to its original position, and that all harnesses are routed correctly. If a wiring clip or retainer breaks, replace it immediately. Wiring is specifically routed to eliminate problems related to engine heat and spray or immersion in liquids. Electrical problems can result if wiring is moved from its original position and is not properly repositioned.

General Lubrication

STARTER

Apply a dab of Pennzoil Premium Plus multipurpose grease onto the starter bendix every month or 50 hours of operation. Your starter has been sprayed with lubrication internally to extend its longevity.

SHIFT AND THROTTLE CABLES

Spray exposed throttle cable and transmission cable ends with Pennzoil Marine Z-M Corrosion Protectant and Lubricant or Pennzoil Premium Plus multipurpose grease. Work the cable back and forth, then spray to completely lubricate. In highly corrosive locations, a complete cable lubrication system may be purchased through your Indmar dealer.

Chapter 7

STORAGE AND WINTER LAY-UP

Storage or winter lay-up requires preparation to prevent damage to the power package. While preparing the power package for winter lay-up, annual maintenance tasks should also be performed.

Without proper preparation, storage over a long period of time may cause internal engine and transmission parts to rust due to lack of lubrication. Also, if the boat is stored where the temperature falls below freezing, any water not drained from the engine may freeze, resulting in severe damage. Damage that is the result of improper storage is not covered under terms of Indmar's limited warranty.



WARNING

Because of the complexity of preparing your engine for winter storage, and the danger of catastrophic engine damage from freezing water in the engine, it is recommended that you have your dealer perform winterization procedures. Damage due to by improper winterization/storage is not covered by product warranty!

To properly winterize your engine, you **MUST** be able to bring the engine up to operating temperature. To accomplish this, your boat must be in the water, or be attached to a water supply using a hose and suitable adapter that will allow an uninterrupted supply of water to the engine.

NOTICE

This procedure covers only the power package portion of your boat. Consult your boat owner's manual or boat manufacturer for specific boat winterizing instructions.

GENERAL PREPARATION

Before starting you will need the following supplies:

- Sta-Bil Gasoline Stabilizer
- 6 quarts of Pennzoil 15W40 Marine Engine Oil (8 quarts for 8.1 Liter)
- Pennzoil PZ3 Oil Filter for 5.7 Liter Carbureted and EFI Engines
- NAPA Gold 1042 Oil Filter for LS1 Engines
- AC-PF454 Oil Filter for 8.1 Liter Engines
- Fuel Filter (If equipped)
- Low Tack Tape
- 4-6 ounces of Pennzoil Marine Fogging Oil
- 1 can Pennzoil Marine Z-M Corrosion Protectant and Lubricant
- Transmission Oil (As Required)
- Pennzoil Premium Plus Multipurpose Grease
- Short Piece of Stiff Wire (Coat hanger wire)
- Pipe Thread Sealant
- Anti-Freeze Tester suitable for Propylene Glycol (Fresh Water Cooled Engines Only)
- Sierra Brand Anti Freeze (As required for Fresh Water Cooled Engines Only)

Fuel System Treatment

1. If the boat is to be placed in storage with fuel in the tank(s) that does not contain alcohol, fill the fuel tank(s) with fresh fuel and a sufficient amount of Sta-Bil gasoline stabilizer to treat the entire tank. Follow instructions on the container.
2. If the boat is to be placed in storage with fuel that contains alcohol, the fuel tank should be drained as completely as possible and Sta-Bil gasoline stabilizer added to any fuel remaining in the tank following the instructions on the container.
3. Start the engine and operate at Idle RPM until the engine reaches normal operating temperature. (If using a hose and adapter, adjust the faucet to avoid over-cooling the engine at low RPM.) Run the engine for at least 15 minutes to ensure that the fuel stabilizer enters the engine's fuel system.



WARNING

Running the engine with the flame arrestor removed increases the possibility of fire or explosion if engine backfire occurs and gasoline fumes are present. If the engine is operated without the flame arrestor secured, extreme care must be taken to ensure that the engine compartment is well ventilated and that no fuel leaks are present.

- Carefully loosen the flame arrestor and lift it far enough to insert the tube of the fogging oil can. Spray 4-6 ounces (118-177 cc) of oil into the throat of the carburetor or throttle body. Shut off the engine. Reattach the flame arrestor and seal with low tack tape.
- Perform annual maintenance, refer to Chapter 6, *Scheduled Maintenance Chart*.
- Loosen all accessory drive belts and check condition. Replace belt(s) if cracked or damaged.
- Drain seawater section of the cooling system.

All Engines:

- Drain water from exhaust manifolds. Uncouple the hose quick disconnect and drain the manifolds. Indmar recommends that you leave the drain plugs out, or the hose uncoupled, until spring.
- Remove both hoses from the seawater pump on the front of the engine. Drain any remaining water from the hoses.
- Remove the raw water pump impeller from the pump housing. Replace the impeller if it shows any signs of damage or wear. Lubricate the impeller with Vaseline and seal in an airtight bag.

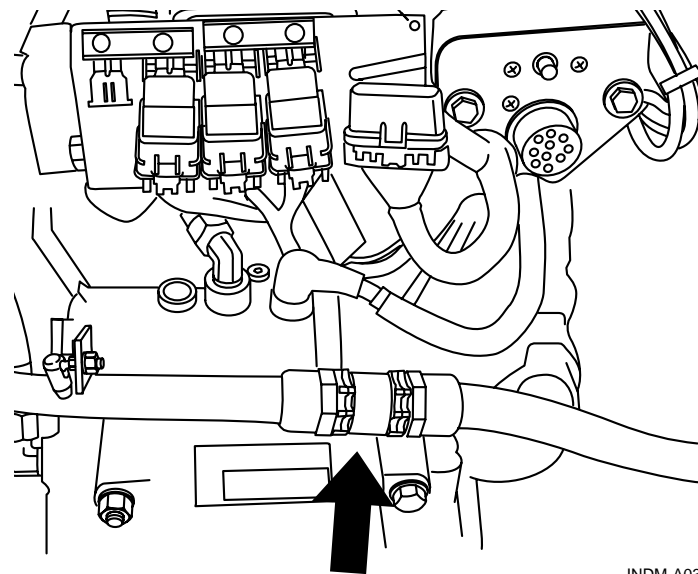

INDM-A038

Figure 7.1 – Quick Disconnect

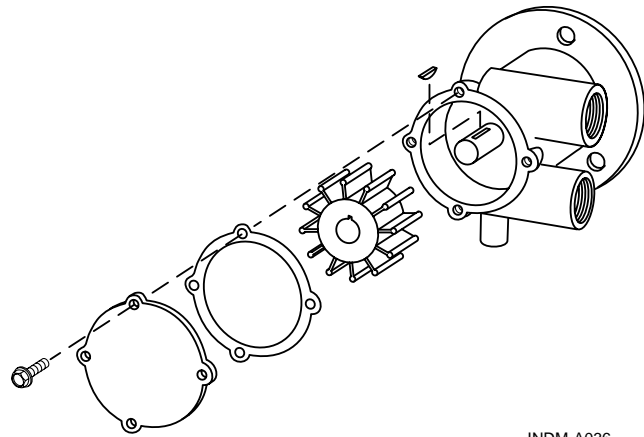

INDM-A036

Figure 7.2 – Raw Water Pump Impeller

4. Remove the hose from the lower (rear) end of the transmission cooler. Inspect the cooler for any debris such as weeds, plastic, etc.

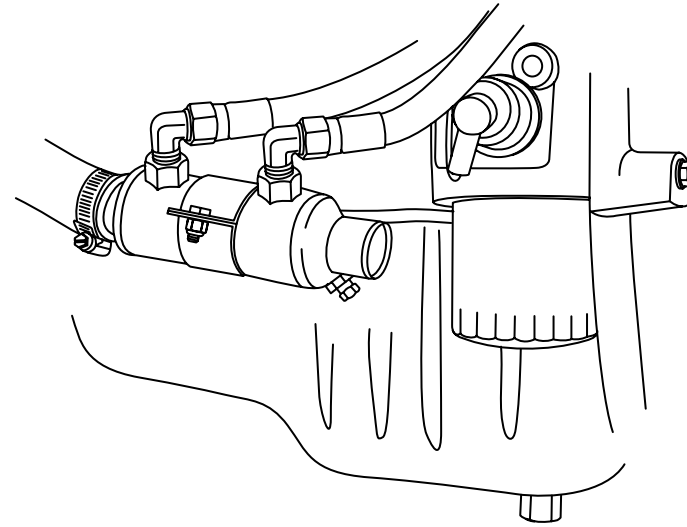

INDM-A009

Figure 7.3 – Transmission Cooler

5. On Walters V-Drive equipped units, remove the two small square headed drain plugs from the front and rear of the upper housing. Look for the words "Water Drain" on the housing.

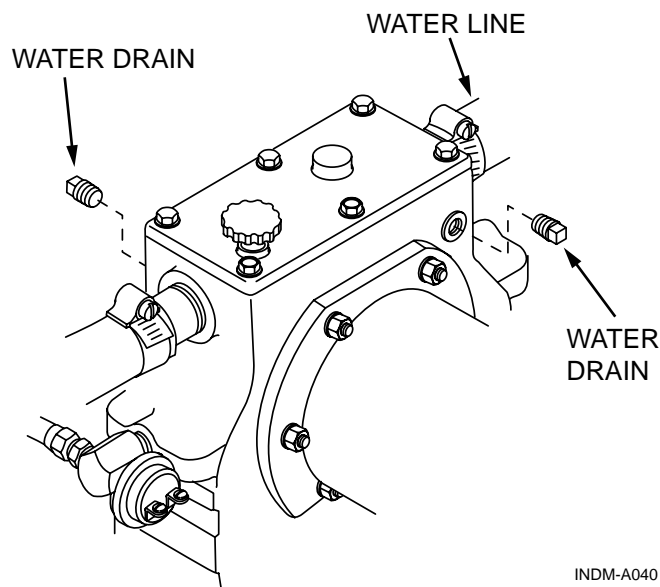

Figure 7.4 – V-Drive Drain Plugs

NOTICE

Placing the drain plugs, impeller, etc. in a plastic bag and attaching the bag to the steering wheel of the boat is a good reminder to reinsert the plugs when you recommission the boat in the spring.

Raw Water Cooled Engines

1. Remove the petcock, drain plug, or sensor from each side of the engine. Indmar suggests removing the petcocks completely, not just opening the petcock drain valve.

NOTICE



Some 5.7 Liter engines have a knock sensor located in the drain location. The knock sensor must be carefully removed to drain that side of the block.

NOTICE

On the 8.1 Liter engine, removing the knock sensor does NOT drain the block. Remove the plugs from the brass fillings on both sides of the engine to drain water from the block.

NOTICE

Placing the drain plugs in a plastic bag and attaching it to the steering wheel of the boat will act as a reminder to reinstall the drain plugs during recommissioning in spring.

2. Use a short piece of stiff wire and poke around in the drain hole to ensure that any rust or scale is broken apart, and the engine drains completely.
3. Disconnect the large diameter hose that runs from the water-circulating pump to the thermostat housing. Make sure all of the water drains from the hose.

Fresh Water Cooled Engines (Except LS1)

1. Remove the raw water inlet and outlet hoses from the intake side of the heat exchanger.
2. Check the level of the coolant on the freshwater side of the heat exchanger. Use the anti-freeze tester to test the strength of the mixture.

NOTICE

A special antifreeze tester designed to be used with Propylene Glycol antifreeze is required to test the strength of the mixture.

3. If the coolant level is low, add a sufficient amount of coolant/water mix to fill the heat exchanger. Use an appropriate mix of Sierra brand antifreeze and distilled water, mixed in accordance with the directions on the container for the anticipated temperatures.
4. If the coolant in the heat exchanger is not strong enough to protect the engine to the lowest anticipated temperature, take your boat to your Indmar dealer for replacement of coolant.

LS1 Fresh Water Cooled Engine

1. Remove the drain plugs on each end of the heat exchanger. Do not remove center (fresh water coolant) plug.

2. Remove the hose from the outlet side of the raw water pump. Push the end of the hose low into the bilge using care not to kink it. Allow both coolers to drain.
3. Coat the threads of the heat exchanger drain plugs with pipe sealant and install.
4. Remove the hose from the rear elbow of one of the exhaust manifolds. Lower the hose into the bilge using care not to kink it. Allow both manifolds to drain.

Drive Train Preparation

1. Change the transmission fluid and clean the filter screen following the instructions in the Transmission Owner's Manual.
2. Remove the attaching hardware from the propeller shaft coupling. Separate the flanges and coat the surfaces with Pennzoil Premium Plus Multipurpose grease.

General Power Package Preparation

1. Clean dirt, grime and grease from painted surfaces of the engine and drive train.
2. Touch-up painted areas of the engine and transmission.
3. Lubricate throttle and shift linkages and cables with Pennzoil Premium Plus Multipurpose Grease.

4. Spray the whole engine with Pennzoil Marine Z-M Corrosion Protectant and Lubricant.
5. Disconnect the battery cables from the battery and charge the battery fully. If you remove the battery from the boat, store it in a cool and dry place.
6. Leave the engine box cover propped open about 2" (50 mm) to ventilate the engine compartment.

REACTIVATING ENGINE AFTER EXTENDED STORAGE

CAUTION

Use caution when connecting the battery cables. Improperly connecting the battery cables or using the wrong battery type can damage electrical components. These damages are not covered by your warranty.

1. Charge and reinstall the battery in the boat. Make sure terminals are clean and tight.
2. Coat the threads of the manifold drain plugs with pipe sealant and install the manifold drain plugs in the back of the exhaust manifold and/or reconnect exhaust manifold drain hoses.
3. Coat the threads of the block drains and petcock drains with pipe sealant and install in the engine block. EFI engines have a knock sensor located in one of the drain holes. If your engine has a knock sensor, it must be reinstalled without using thread sealant. Do not over tighten the knock sensor. Torque specification for the knock sensor is 14-16 lb. ft. (19 to 21.5 Nm)
4. On Walter V-Drive units, coat the threads on the drain plugs with pipe sealant and reinstall on the front and rear of the transmission housing.
5. Reinstall the raw water pump impeller, be sure to use a new gasket for the housing cover. Re-attach the inlet and outlet hoses to the raw water pump.
6. Reattach the large diameter hose to the water-circulating pump.
7. Reattach the water hose to the transmission cooler.
8. On fresh water cooled models, reattach the raw water inlet and outlet hoses.
9. Install a new set of spark plugs in the engine.
10. Inspect accessory drive belts and tighten to the proper tension if necessary.
11. Check condition of the distributor cap and rotor, and replace if worn, damaged or corroded.
12. If the fuel tank was drained, fill tank with fresh fuel that does not contain alcohol.
13. Check all fluid, oil and coolant levels on engine and drive train.
14. Check engine compartment and bilge for nesting animals. Clean as necessary. Check for any damage or evidence of fluid leaks.

15. Remove tape from flame arrestor. Check alignment between the output flange on the transmission and the prop shaft flange. If the maximum feeler gauge that can slip between the flange faces at any point is 0.003" (0.08 mm), the unit is properly aligned. If a thicker gauge can be inserted at any point, the engine must be readjusted until proper alignment is obtained.

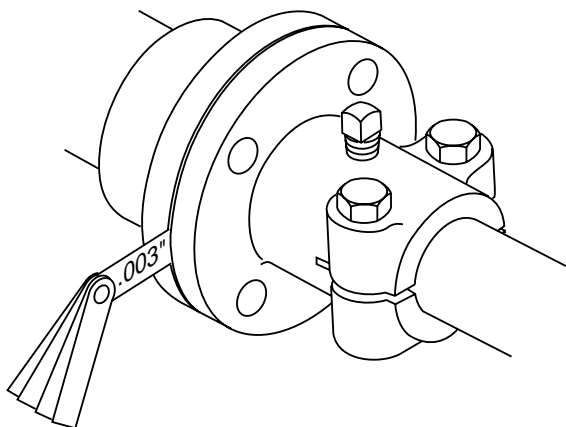

INDM-A037

Figure 7.5 – Prop Shaft Flange Alignment

NOTICE



With the boat in the water or a hose and adapter installed, cycle the key switch ON, then OFF, for five second intervals 8-10 times before cranking the engine to allow the fuel pump to prime the fuel lines.

16. Review boat manufacturers starting procedure.
17. Start the engine. If you experience a no-start condition, do not crank the engine for more than 15 seconds without allowing a two minute cool-down period. When the engine starts, keep a close watch on the gauge readings. Check all of the hoses and drain plugs for leaks. Listen for abnormal noises. Run the engine long enough to reach normal operating temperature and re-inspect for leaks. If no leaks are found, the boat is ready for operation.

Chapter 8

TROUBLESHOOTING

Your Indmar engine is manufactured under strict quality control standards. It is tested along with a full spectrum gas analysis. It is operating at optimum levels before it is shipped. Indmar engines have the exclusive Indmar 3-year limited warranty.

Difficulties can occur. Use the following problem diagnosis charts to help pinpoint problems. In most cases, you will need the assistance of your Indmar dealer to correct the cause of the problem.

Poor Gas Mileage

1. Fouled spark plugs
2. Plugged flame arrestor
3. Poor driving habits
4. Closed or partially closed choke (Carbureted Engines Only)
5. Plugged positive crankcase ventilation system
6. Black smoke at exhaust outlet shows rich gas mixture
7. Excessive boat loads (weight)
8. Damaged or dirty hull
9. High altitude adjustment required
10. Adjustment for temperature extremes required

Hard Cold Start

1. Weak or discharged battery
2. Choke held open (Carbureted Engines Only)
3. Loose coil or ignition wires
4. Engine Flooded
5. Fouled spark plugs
6. Lack of fuel at carburetor (Carbureted Engines Only)
7. Battery cables loose or corroded
8. Loose electrical grounds at engine
9. Ignition switch problems
10. Dirt or water in fuel system
11. Engine needs tune-up

Poor High Speed Performance

1. Fouled spark plugs, incorrect spark plug gap or heat range
2. Closed or partially closed choke (Carbureted Engines Only)
3. Dirt or water in fuel
4. Lack of fuel in carburetor (Carbureted Engines Only)
5. Restricted exhaust system
6. Plugged flame arrestor

7. Insufficient air supply to engine
8. Engine needs tune-up
9. Damaged or incorrect propeller
10. Engine needs to be adjusted for high altitude operations
11. Engine needs to be adjusted for temperature extremes

Engine Cranks / Won't Start

1. Weak or shorted coil, no spark at plugs
2. Loose engine grounds
3. Lack of fuel at carburetor (Carbureted Engines Only)
4. Weak or discharged battery
5. Boat Engine Safety switch not attached
6. Vapor lock

Idle — Misses or Runs Rough

1. Spark plugs fouled or cracked
2. Spark plug or distributor wires loose or shorted
3. Plugged positive crankcase ventilation system
4. Engine in need of tune-up
5. Engine needs to be adjusted for high altitude operations
6. Engine needs to be adjusted for temperature extremes
7. Carburetor out of adjustment (Carbureted Engines Only)

Hard Start Hot

1. Flooding condition
2. Loose electrical ground at engine
3. Closed choke (Carbureted Engines Only)
4. Plugged flame arrestor
5. Fouled spark plugs
6. Loose coil or ignition wires
7. Battery cables loose or corroded
8. Weak or discharged battery
9. Vapor lock

Engine Won't Crank

1. Weak or discharged battery; loose or corroded battery cables
2. Defective Neutral Safety Switch or adjustment needed
3. Defective starter motor
4. Ignition switch problems
5. Hydrostatic lockup — remove spark plugs to look for water or gasoline in cylinders
6. Seized engine — turn crank pulley with socket and ratchet

Appendix – A



MAINTENANCE COMPONENTS AND FLUIDS

Engine Oil	15W-40 Pennzoil Marine, API Service SJ/CG4 Racing Oil
Engine Oil Filter	All 5.7 Liter except LS1 - Pennzoil PZ3 LS1 - NAPA Gold 1042 8.1 Liter - AC-PF454
Engine Coolant (for closed systems)	Sierra brand propylene glycol
ZF Hurth Transmission Fluid & V-Drive	Pennzoil Type A Dexron II, III or Dexron/Mercon
Walters V-Drive Oil	SAE 30 Pennzoil Motor Oil
Engine Fuel (for storage)	STA-BIL fuel stabilizer
Engine Cables (for corrosion protection)	Pennzoil Marine Z-M Corrosion Protectant and Lubricant
Starter Bendix	Pennzoil Premium Plus Multipurpose Grease
Fuel Filter	In-Line - Indmar 556003 Spin-on - Indmar786020

Alternator Belt	All 5.7 Liter except LS1 - Indmar 725018 LS1 serpentine - Indmar 725028 8.1 Liter - Indmar 725030
Thermostat	Raw water cooled - Indmar 985009 Closed cooled - Indmar 986034 LS1 - Indmar 986110
Spark Plugs	 All 5.7 Liter except LS1 – AC Delco MR43LTS LS1 – AC Delco AC41-931 8.1 Liter – Nippon Denso TJ14R-P15
Surface Corrosion Protection	Pennzoil Marine Z-M Corrosion Protectant and Lubricant
Engine Fogging Oil	Pennzoil Marine Fogging Oil

Appendix – B

ENGINE SPECIFICATIONS

	5.7L Carb	5.7L TBI	5.7L MPI	LS1 Corvette	8.1L MPI
Number of Cylinders	V-8				
Displacement	350 CID (5.7L)				496 CID (8.1L)
Bore/Stroke	4.0012 x 3.480 in (101.63 x 88.39 mm)			3.898 x 3.622 in (99 x 92 mm)	4.25 x 4.37 in (108 x 111 mm)
Compression Ratio	9.4:1			10.1:1	9.1:1
Compression Pressure (Note 1)	Minimum 100 PSI (690 kPa)				
Idle RPM in Neutral (Note 2)	650 ± 50 RPM				
Operating Range at WOT	4400-4800 RPM		4600-5200 RPM	5200-5600 RPM	5000-5400 RPM
Oil Pressure at Idle	4PSI (41kPa) Minimum - Hot				5 PSI (34kPa) Minimum
Oil Pressure at 2000 RPM	18 PSI (124 kPa) Minimum Hot				10 PSI (69kPa) Minimum
Oil Filter	Pennzoil PZ3, AC-PF25			Napa Gold 1042	AC-PF454
Fuel Pump Pressure	8 PSI Max (55.2 kPa)	30 PSI Min at Keyup (206.8 kPa)	40 PSI Min at Keyup (275.8 kPa)	50 PSI Min at Keyup (344.7 kPa)	
Electrical System	12 Volt DC Negative (-) Ground				
Minimum Battery Requirements	650 cca/700 mca/120Ah				
Firing Order	1-8-4-3-6- 			1-8-7-2-6-5-4-3	
Spark Plug Type	MR43L 			AC 41-931	Nippon Denso TJ14R-P15
Spark Plug Gap	0.030 in (.76 mm)	0.045 in (1.1 mm)		0.050 in (1.3 mm)	
Base Timing at 1000 RPM (Note 3)	10° Before Top Dead Center			Non Adjustable	
Thermostat	160° F (71° C)				

Fluid Capacities	5.7L Carb	5.7L TBI	5.7L MPI	LS1 Corvette	8.1L MPI
Crankcase (With Filter)(Note 4)	5.5 Quarts (5.25 L) With Filter				8 Quarts (7.6 L)
Closed Cooling System (Note 5)	12-14 Quarts (11.4-13.3 L)				14-16 Quarts (13.2-15.1 L)
In-Line Transmission (Note 4)	2.12 Quarts (2.0 L)				
Walters V-Drive Transmission (Note 4)	2 Pints (0.95 L)				Not Used
Hurth V-Drive Transmission (Note 4)	4.4 Quarts (4.16 L)				

Notes

- 1) Minimum recorded compression in any one cylinder should not be less than 70% of the highest recorded cylinder.
- 2) Measured using an accurate shop tachometer at normal operating temperature. Idle RPM on EFI models is not adjustable.
- 3) Timing must be set using special procedures indicated in the appropriate service manual. Timing cannot be set using conventional methods. Special tool(s) required.
- 4) Always use dipstick to determine exact quantity of oil required. Do not fill above "FULL" mark.
- 5) Do not over fill. Correct level is 3/4" below filler neck when coolant is warm.

Appendix – C

LIMITED WARRANTY

What Is Covered by Warranty

Any part(s) that fails as the result of defects in material and workmanship will be replaced at no charge to the customer under the terms of the Limited Product Warranty.

What Is Not Covered by Warranty

- Shop supplies used in performing warranty work (i.e. rags, sealants, lubricants, etc.).
- Incidental and consequential damages (storage charges, telephone or rental charges of any type, inconvenience or loss of time or income).
- Minor adjustments and tune-ups; including checking, cleaning or adjusting spark plugs, carburetor setting, filters, belts, controls and checking lubrication.
- Failure caused by neglect, lack of maintenance, accident, abnormal operation, improper installation, improper preparation, improper winterization, improper dealer set-up or improper service or normal wear and tear.
- Haul-out, launch, towing charges; removal and/or replacement of boat partitions or material because of boat design for necessary access to the Product.
- Transportation charges and/or travel time.
- Service requested by customer other than that necessary to satisfy the warranty obligation.
- Use of other than Indmar replacement parts and labor to install these parts when making warranty repairs.
- Oils, lubricants or fluids used in normal maintenance.
- Participation in or preparing for racing or other competitive activity.
- Starter motors and/or armatures or field coil assembly, which are damaged from excessive cranking, condensation, or submersion.
- Water entering the engine via the intake or exhaust system or submersion.
- Use of fuels and lubricants that are not suitable for use with or on the product.

- Failure of any parts caused by lack of cooling water, which results from starting motor out of water or foreign materials blocking intake passages.
- Air freight, next-day or second-day air, or any special delivery fees, unless authorized by Indmar prior to ordering of parts.
- Certain parts may be tested on receipt by Indmar. Parts found to be free of defects will be returned to the dealer and no credit will be issued
- Indmar reserves the right to retrieve run time/run condition data from an engines Electronic Control Module prior to granting warranty coverage on the product.

Limited Warranty

Indmar Products Co., Inc., 5400 Old Millington Road, Millington, Tennessee 38053 ("Indmar") warrants marine propulsion engines sold by it (the "Product"):

NOTICE

Indmar reserves the right to retrieve run time/run condition data from an engines Electronic Control Module prior to granting warranty coverage on the product.

Product installed in boats manufactured by an approved manufacturer (OEM):

- a. For a period of thirty-six (36) months commencing from the date of purchase or the date of commencement of the product use, whichever sooner occurs, in the case of non-commercial use.
- b. For a period of thirty-six (36) months commencing from the lease date if lease is for private use and is for a time period of not less than two years. Or
- c. For a period of three (3) months commencing from the date of purchase or lease inception or the date of commencement of the product use, whichever sooner occurs, in the case of commercial use.

Repowers or installation in other than boats manufactured by an approved manufacturer (OEM)

- a. For a period of twelve 12 months commencing from the date of purchase or the date of commencement of the product use, whichever sooner occurs, in the case of non-commercial use. Or
- b. For a period of three (3) months commencing from the date of purchase or the date of commencement of the product use, whichever sooner occurs, in the case of commercial use.

This limited warranty is granted SOLELY upon the following terms

- a. **Persons Applicable.** This warranty is extended to the original retail purchaser or original lessor in the case of a leased boat. If the boat is sold or traded prior to the end of the warranty period, the remainder of the product warranty is transferable to the new owner or lessor. A fee of \$200.00 will be required to transfer the warranty. Warranties of any nature to any other person are hereby specifically excluded.
- b. **Coverage.** The product is warranted to be free from material defects in material and workmanship under normal use and service during the period of this Limited Warranty. Components that are "worn-out" from use are not covered under the terms of this warranty. If the product or defective part thereof is, upon examination, determined to be thus defective, Indmar shall repair or, at its sole option, provide a replacement of equivalent quality (new or rebuilt, at its option.) Indmar's sole obligation under this Limited Warranty is to repair or at its sole option, to provide a replacement of equivalent quality (new or rebuilt, at its option).
- c. **Procedure.** Within 10 days from the date of purchase by the original retail purchaser of the product or beginning of lease period, the Indmar Warranty Registration Card must be properly completed and mailed to Indmar. In the case of a leased boat, a copy of the lease contract showing the length of the lease must also be supplied to Indmar. In the case of a warranty transfer to a subsequent owner or lessor, the new owner/lessor information along with a check for \$200.00 made payable to Indmar Warranty Transfer must be sent within 60 days of transfer. Any transfer must be approved by Indmar. In the case of transfer of a leased boat, a copy of the lease contract showing the length of the lease must also be included. No warranty claims will be honored without prior receipt of the Indmar Warranty Registration Card. For warranty claims to be asserted hereunder, the Product or defective part thereof, together with a written notice of itemized defects must be returned to the retailer from whom the product was purchased or to any other convenient Indmar dealer. To obtain the location of an authorized Indmar dealer or service center in your area, write to Indmar requesting such information. In the event that the local Indmar dealer is unable to remedy a warranted defect in the Product, the Product or defective part thereof, together with a written notice of itemized defects, must be returned to Indmar with freight and insurance charges prepaid. All insurance and freight charges and return charges by Indmar of the Product (or its substitute) to the retail purchaser shall be paid by the purchaser. Expenses for labor incurred by Indmar in the repair of any warranted product shall be paid by the retail purchaser or lessor to the extent that such expenses for labor exceed the specified service rates of Indmar in effect at the date of purchase by Indmar. A schedule of service rates of Indmar may be obtained from any authorized Indmar dealer.
- d. **Trade Accessories.** No warranty of any character is made with respect to trade accessories not manufactured by Indmar.

- e. Voiding Warranty. This warranty is specifically voided and shall NOT apply under the following conditions:
- i. When the product or any part thereof is subjected to accident, alteration, modifications, abuse, misuse, neglect, or improper maintenance.
 - ii. When the product is serviced by unauthorized persons; or
 - iii. When damage to the product results from causes not arising from defects in material and/or workmanship.

THE WARRANTY STATED ABOVE IS A LIMITED WARRANTY AND IT IS THE ONLY WARRANTY MADE BY INDMAR. INDMAR DOES NOT MAKE ANY OTHER WARRANTIES EXPRESS OR IMPLIED. THERE ARE EXPRESSLY EXCLUDED ALL WARRANTIES OF MERCHANTABILITY AND FITNESS FOR A PARTICULAR PURPOSE. INDMAR SHALL HAVE NO LIABILITY WITH RESPECT TO ITS OBLIGATIONS UNDER THIS WARRANTY OR OTHERWISE FOR CONSEQUENTIAL, EXEMPLARY, INCIDENTAL OR PUNITIVE DAMAGES EVEN IF IT HAS BEEN ADVISED OF THE POSSIBILITY OF SUCH DAMAGES. THE STATED EXPRESS WARRANTY IS IN LIEU OF ALL LIABILITIES OR OBLIGATIONS OF INDMAR FOR DAMAGES ARISING OUT OF OR IN CONNECTION WITH THE DEVELOPMENT, DELIVERY, USE, OR PERFORMANCE OF THE PRODUCT. IN ANY EVENT THE LIABILITY OF INDMAR FOR ANY REASON AND UPON ANY CAUSE OF ACTION WHATSOEVER SHALL BE LIMITED TO THE AMOUNT THEN PREVIOUSLY PAID FOR THE PRODUCT.

Indmar does not authorize any person, firm or corporation to alter this Limited Warranty or create any other obligation relating to the product. This warranty gives you specific legal rights, and you may also have other rights which vary from state to state.

Indmar Products Co., Inc.
5400 Old Millington Road
Millington, Tennessee 38053

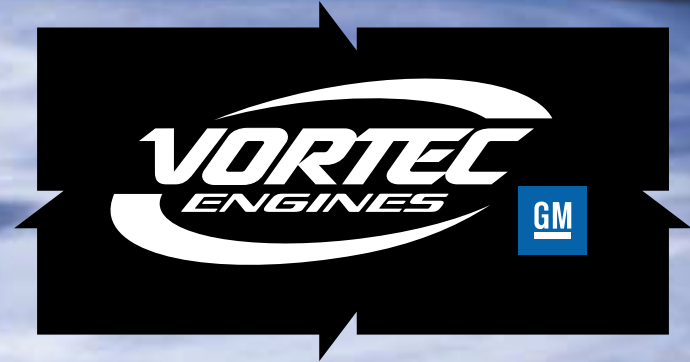

SAE 15W-40

Indmar
M A R I N E E N G I N E S

5400 Old Millington Road
Millington, TN 38053
www.indmar.com

Part No. OM0502-01

Ken Cook Co.

Printed in U.S.A.